

RoHS

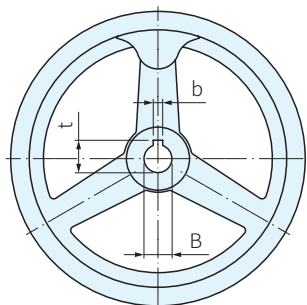

本體		把手	
材質	處理	材質	處理
鋁合金	去毛頭，輪緣拋光	鋼	鍍鋅



輪幅=3

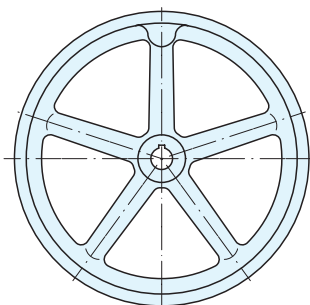

輪幅=5

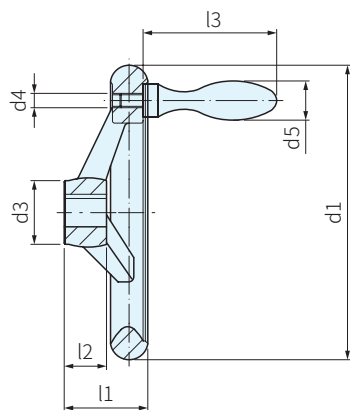

B(小) 品號	質量 g	庫存	B(大) 品號	質量 g	庫存	d1	B(H7)		d3	d4	d5	l1 ≈	l2	l3 ≈	輪幅	特性	把手 24460
							小	大									
24590.0200	150	•	24590.0201	150	•	80	10	12	24	M6	16	29	16	49	3	無鍵槽 有迴轉 把手	16
24590.0205	210	•	24590.0206	220	•	100	10	12	26	M6	16	33	17	49	3		16
24590.0210	340	•	24590.0211	340	•	125	12	14	28	M8	20	36	18	61	3		20
24590.0220	615	•	24590.0221	615	•	160	14	16	32	M10	25	40	20	75	3		25
24590.0230	970	•	24590.0231	970	•	200	18	22	38	M10	25	45	24	75	3		25
24590.0240	1885	•	24590.0241	1885	•	250	22	26	45	M12	32	50	28	95	5		32
24590.0245	2885	△	24590.0246	2885	△	315	26	30	53	M12	32	56	33	95	5		32
24590.0250	4250	△	24590.0251	4250	△	400	30	34	65	M16	36	63	38	106	5		36
24590.0300	150	•	24590.0301	150	•	80	10	12	24	M6	16	29	16	49	3	有鍵槽 有迴轉 把手	16
24590.0305	210	•	24590.0306	210	•	100	10	12	26	M6	16	33	17	49	3		16
24590.0310	340	•	24590.0311	340	•	125	12	14	28	M8	20	36	18	61	3		20
24590.0320	615	•	24590.0321	615	•	160	14	16	32	M10	25	40	20	75	3		25
24590.0330	970	•	24590.0331	970	•	200	18	22	38	M10	25	45	24	75	3		25
24590.0340	1885	•	24590.0341	1885	•	250	22	26	45	M12	32	50	28	95	5		32
24590.0345	2885	△	24590.0346	2885	△	315	26	30	53	M12	32	56	33	95	5		32
24590.0350	4250	△	24590.0351	4250	△	400	30	34	65	M16	36	63	38	106	5		36

訂貨：  交期：  天 ·  
24590.0200  天 △

DIN6885 鍵槽規格									
B	10	12	14	16	18	22	26	30	34
b	3.0	4.0	5.0	5.0	6.0	6.0	8.0	8.0	10.0
t	11.4	13.8	16.3	18.3	20.8	24.8	29.3	33.3	37.3

PS. 備註

- 可搭配手輪端蓋SGR184、SGR184.5、22270，請參閱本單元
- 迴轉把手24460，請參閱把手單元

